

REVAMPING UPGRADING RETROFITTING SERVICES



A subsidiary of VINCI ENERGIES

BOOST THE HEART OF YOUR PROCESS

Revamping is not just servicing and overhauling a used machine or installation. It means renewing and updating a system with the most recent solutions so as to increase efficiency and productivity.

Your installation is old, and the mixer has become the bottleneck of your process?

Your current mixer is not as flexible as your production needs?

Change it for a brand new SOFRADEN mixer!

.....
We can provide you with a **turnkey solution**, including:

- Dismantling of your current equipment
 - Modification of the supporting structures or platform (under some conditions)
 - Supply and installation of the new mixer, and any other new equipment (hoppers...)
-

REFERENCES

Saint-Gobain Weber, Bostik, Cermix...

OUR ASSETS

- Turnkey service
- Minimum interference with production (usually a 3 week project, working in 2 shifts)
- MASE accreditation (high-level HSE standard) bears witness to SOFRADEN's ongoing commitment to safety, health and the environment

Example of a 'revamping' project, in a batch process unit for powders:

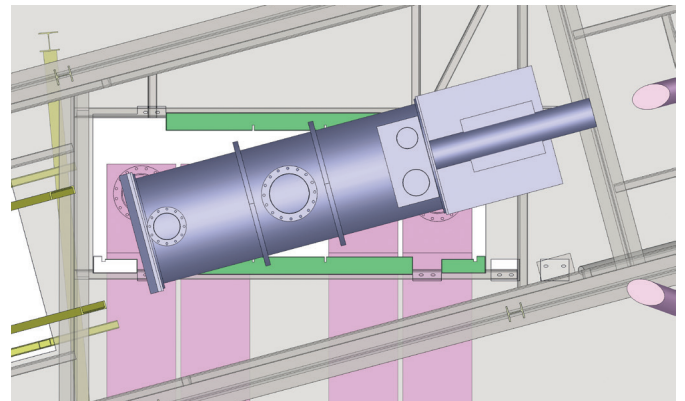

Original configuration of the installation, with a mixer with 2 discharge nozzles

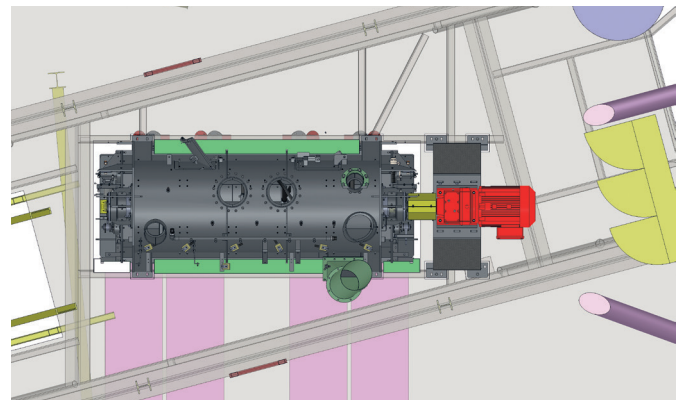

New configuration of the installation, with a SOFRADEN mixer MIB VI

Scope of the project:

- Original mixer with discharge nozzles changed for a new MIB SOFRADEN mixer, with a full discharge door and CIP system
- Modification of the supporting steel structure, in order to align the new mixer with the packers
- Change of the upstream and downstream hoppers

> Plant ready to run after 3 weeks

Turn your project into success,
thanks to our skills and know-how.



REVAMPING UPGRADING RETROFITTING SERVICES

 **SOFRADEN**

A subsidiary of  **VINCI**
ENERGIES

We are also able to modify and **upgrade** your existing machine, in order to improve their performances. For example, if the bottleneck of your process is caused by its discharge system, we can change it for one of our own solutions.

Change of the OEM discharge nozzles of a mixer for our own designed discharge traps



> Discharge time divided by 2

Other example: if the cause of your process bottleneck is too long mixing time, we can equip your mixer with SOFRADEN patented tools, which improve the dispersion action, and reduce the dispersion time required.

In addition to the "revamping & upgrading" services, we also have a **retrofitting service** for mixers.

For example, your mixer is old, and its OPEX has become huge due to frequent maintenance operations?

Or you have bought a second-hand SOFRADEN mixer, and you would like to renovate it before using it?

We can rebuild your mixer, and equip it with the latest solutions integrated on our current machines. With this almost brand-new machine, you will have peace of mind for the next 10 years!

A second-hand SOFRADEN MIB086L VI mixer, before renovation



> The same machine, after its renovation in our workshop



SOFRADEN

24 rue du Puits Rochefort - BP 290
42014 Saint-Étienne Cedex 2 - FRANCE

Phone : +33 (0)4 77 41 02 04

Fax : +33 (0)4 77 41 00 20

www.sofraden.com

